



forestconcepts™

Biochar Production Facility Design Process and Tools

Dave Lanning
Senior Engineer
Forest Concepts, LLC
dlanning@forestconcepts.com

Cooperators:
US Dept of Energy
C6 Forest to Farm
By Design Engineering

Agenda

- Background
- Appreciative Design Process
- SiPS TEA Software
- Wrap up

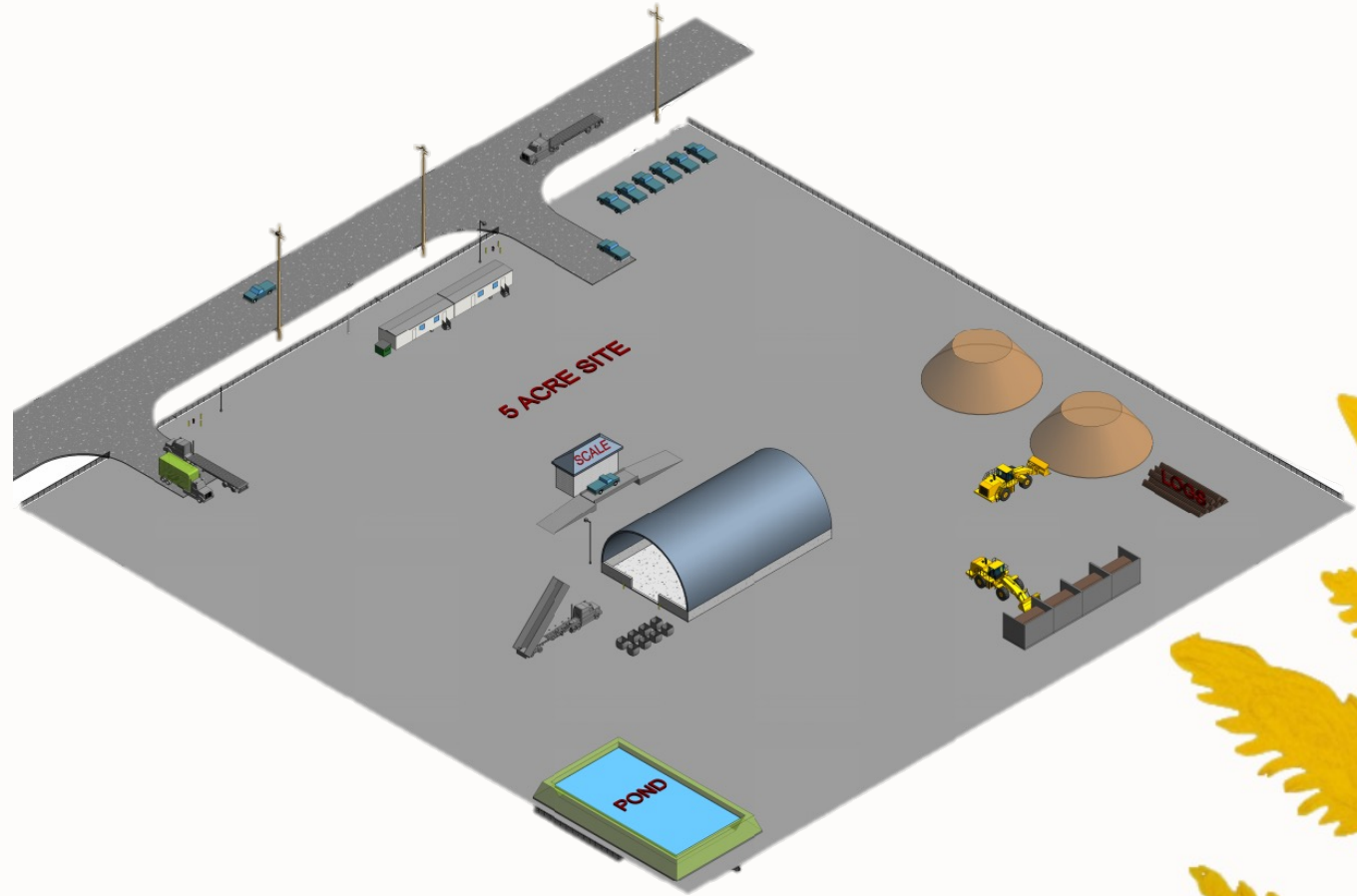

Background

- Biochar production facility
- C6 Forest to Farm siting facility in North-Central Washington
- Community scale (1 odt/hr equivalent)

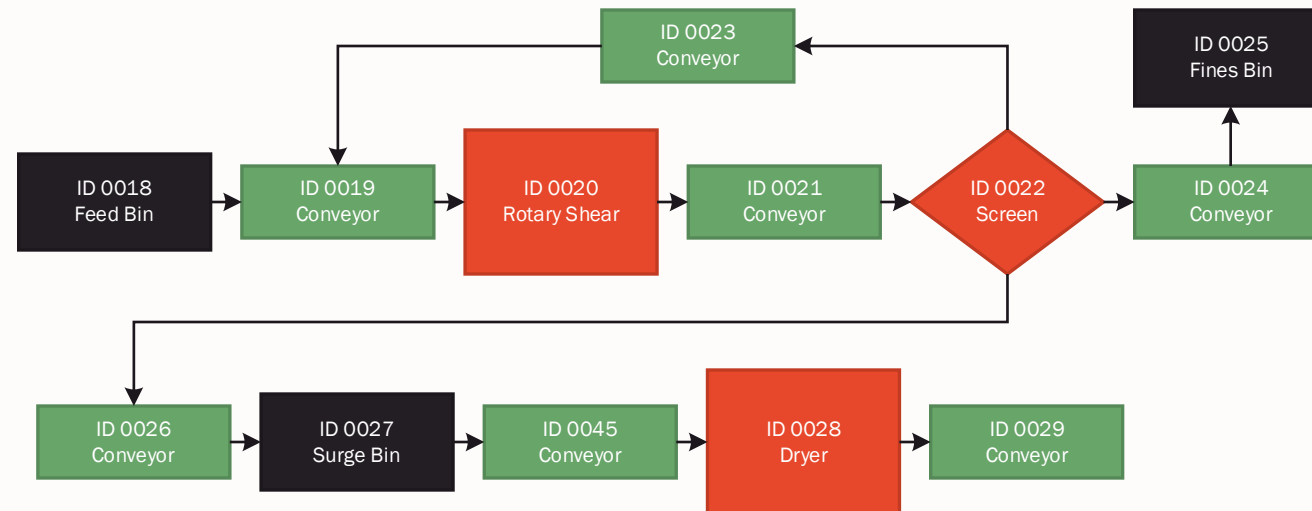

Appreciative Design

- Appreciate beliefs, values, and needs of individuals and institutions (Soft Systems Methodology)
- Treat beliefs, values and other “externalities” just like hard constraints (Policy Analysis)
- Follow accepted design methodology (Suh’s Axiomatic Design)



Appreciative Design (2)

Community Engagement

- Stakeholder identification and surveys
 - Weight stakeholder groups as needed
 - Regulatory
 - Owner
 - Operator
 - Neighbor

Axiomatic Design (Nam Suh)

- Three components
 - Functional Requirements (FRs) (objectives)
 - Constraints (Cs)
 - Design Parameters (DPs) (solutions)
- Two Axioms
 - Independence among Functional Requirements
 - Best DPs have least information content

Sub	ID	Description	Weight	% Weight	Constraint	BE&E Smart Container (20')	Vibra LBB 5-200 live bottom bin	IMS 144001 Surge bin
1	18.1	Hold green chips / hogfuel for 30 minutes of rotary shear run time	17.4	8.5%	1) Chip bulk density as monthly (MC) is 243 kg/cu.m. 2) Rotary shear (ID 0020) has a maximum demand of 1.67 ODT/hr. Outflow rate is Y	1/2 shift, 640 cu.ft	200 cu.ft	29 Cu.ft
2	18.2	Accommodate conveyor input of hogfuel	31.0	15.2%		closed or open top option	round outfeed profile, batch process	Outfeed customizable
3	18.3	Accommodate wheel loader input of hogfuel	21.0	10.3%	1) Side height maximum is X 2) Loading width minimum is Y	Large receiving input - can be specified	14' tall 8ft diam round infeed opening	4.5' tall
4	18.4	Provide output flow without jamming or plugging	41.0	20.1%	1) Maximum particle size is X 2) Flowability index is Y 3) Minimum opening is Z	Live bottom smart floor	live bottom	no live bottom
5	18.5	Trap magnetic metals from the biomass	1.0	0.5%	1) Outfeed flow depth across metal trap not more than 2-inches deep and velocity less than X	No magnet	No magnet	No magnet
6	18.6	Detect full state for upstream system control	15.0	7.3%		detect visually	no sensors or view ports	view ports
7	18.7	Detect low level state for upstream system speed control	22.8	11.2%		accurate discharge rate. Metering option	detect visually but cannot view internally	view ports
8	18.8	Minimize capital cost	20.3	9.9%		\$119,000	TBD	\$3,000

Sub	ID	Description	Weight	% Weight	Constraint	BE&E Smart Container (20')	Vibra LBB 5-200 live bottom bin	IMS 144001 Surge bin
1	18.1	Hold green chips / hogfuel for 30 minutes of rotary shear run time	17.4	8.5%	1) Chip bulk density as monthly (MC) is 243 kg/cu.m. 2) Rotary shear (ID 0020) has a maximum demand of 1.67 ODT/hr. Outflow rate is Y	1/2 shift, 640 cu.ft	200 cu.ft	29 Cu.ft
2	18.2	Accommodate conveyor input of hogfuel	31.0	15.2%		closed or open top option	round outfeed profile, batch process	Outfeed customizable
3	18.3	Accommodate wheel loader input of hogfuel	21.0	10.3%	1) Side height maximum is X 2) Loading width minimum is Y	Large receiving input - can be specified	14' tall 8ft diam round infeed opening	4.5' tall
4	18.4	Provide output flow without jamming or plugging	41.0	20.1%	1) Maximum particle size is X 2) Flowability index is Y 3) Minimum opening is Z	Live bottom smart floor	live bottom	no live bottom
5	18.5	Trap magnetic metals from the biomass	1.0	0.5%	1) Outfeed flow depth across metal trap not more than 2-inches deep and velocity less than X	No magnet	No magnet	No magnet
6	18.6	Detect full state for upstream system control	15.0	7.3%		detect visually	no sensors or view ports	view ports
7	18.7	Detect low level state for upstream system speed control	22.8	11.2%		accurate discharge rate. Metering option	detect visually but cannot view internally	view ports
8	18.8	Minimize capital cost	20.3	9.9%		\$119,000	TBD	\$3,000
9	18.9	Minimize maintenance required	14.3	7.0%		minimal civil work		



SiPS TEA Software - Overview

Simulation of Processing Systems for Techno-Economic Analysis

- Enables developers to quickly analyze design alternatives for community scale biomass processing centers
- Enable rapid creation of flexible TEA simulations
- Model multiple lines of biomass flow (split, combine, recirculate)
- Add / reorder equipment connections automatically
- Model non-steady state conditions and sensitivities
- Track biomass properties through the system
 - Size
 - Density
 - Moisture content



SiPS TEA - Equipment

Excel Based Equipment List

- Equipment Name
- Capacity (Mg/hr)
- CAPEX (\$)
- Electrical Power (HP)
- Natural Gas Consumption (MMBtu/hr)
- R&M Rate (% of CAPEX)
- Life (h)
- Footprint (ft²)
- Covered (Y/N)
- Volume (m³)
- Expandable to other parameters

Name	Throughput (Mg/hr)	Capex (\$)	HP	NG Power Cons (mmbtu/hr)	R&M rate (%)	Life (h)	Sqft	Covered?	Volume (m ³)
Bin.Surge.IMS.144025.336	1.4	\$ 15,083.00	NA	NA	10%	50000	20	no	9.5
Bin.LiveBottom.BE&E.SMARTContainer.640	2.7	\$ 119,000.00	5	NA	10%	100000	160	no	18.1
Bin.Supersack.McMaster.3791K14.32	0.1	\$ 94.50	NA	NA	10%	10000	9	yes	0.9
Bin.LiveBottom.BE&E.3x5x5.32	0.1	\$ 44,000.00	1	NA	10%	100000	20	no	0.9
Bin.Metering.Warren&Baerg.5.135	0.6	\$ 120,000.00	5	NA	10%	50000	144	no	3.8
Bin.Metering.Warren&Baerg.10.270	1.1	\$ 148,889.00	5	NA	10%	50000	144	no	7.6
Bin.Metering.Warren&Baerg.15.405	1.7	\$ 168,149.00	5	NA	10%	50000	144	no	11.5
Conveyor.Belt.INTERQUIP.EK450.7	45.4	\$ 10,556.00	3	NA	10%	50000	12	yes	
Conveyor.Belt.INTERQUIP.EK450.16	45.4	\$ 13,500.00	3	NA	10%	50000	28	yes	
Conveyor.Belt.INTERQUIP.EK450.30	45.4	\$ 15,000.00	3	NA	10%	50000	53	yes	
Conveyor.Belt.INTERQUIP.LKS450.10	90.0	\$ 14,000.00	1	NA	10%	50000	25	yes	
Conveyor.Belt.INTERQUIP.LKS450.14	90.0	\$ 15,000.00	1	NA	10%	50000	35	yes	
Conveyor.Belt.INTERQUIP.LKS450.18	90.0	\$ 16,000.00	1	NA	10%	50000	45	yes	
Conveyor.Belt.BE&E.18S-21L.21	10.0	\$ 28,700.00	5	NA	10%	100000	80	no	
Conveyor.Belt.BE&E.18S-23L.23	10.0	\$ 29,000.00	5	NA	10%	100000	80	no	
Conveyor.Belt.BE&E.18S-35L.35	10.0	\$ 39,800.00	5	NA	10%	100000	80	no	
Comminution.RotaryShear.ForestConcepts.P24M-200e.6mm	6.8	\$ 479,301.45	200	NA	10%	146000	100	yes	
Comminution.RotaryShear.ForestConcepts.P24M-150e.6mm	6.8	\$ 385,209.00	150	NA	10%	146000	100	yes	
Comminution.RotaryShear.ForestConcepts.M24M-30e.4mm	0.68	\$ 113,903.74	30	NA	10%	73000	29	yes	
Comminution.RotaryShear.ForestConcepts.M24M-30e.2mm	0.68	\$ 115,415.17	30	NA	10%	73000	29	yes	
Comminution.RotaryShear.ForestConcepts.M24M-30e.6mm	0.68	\$ 113,148.02	30	NA	10%	73000	29	yes	
Comminution.Hammermill.BLISS.eliminator	17.2	\$ 51,904.00	400	NA	10%	50000	50	yes	
Dryer.Downdraft.NorrisThermal.560B-X4	2.7	\$ 300,000.00	60	7	10%	168000	1216	yes	
Dryer.Downdraft.NorrisThermal.207B-2	0.3	\$ 200,000.00	7.5	2	10%	168000	120	yes	
Dryer.Rotary.ZIMachinery.JTSG2010/3	1.8	\$ 300,000.00	121	5	10%	168000	1550	yes	
Dryer.Downdraft.ForestConcepts.123b	0.2	\$ 437,467.14	5	0.65	10%	168000	75	yes	
Screen.Gyratory.BM&M.4x10SS	5.0	\$ 70,000.00	5	NA	10%	30000	77	yes	
Screen.Gyratory.BM&M.3x8SS	3.0	\$ 65,000.00	5	NA	10%	30000	47	yes	
Screen.Orbital.ForestConcepts.OS 2448-3	1.4	\$ 43,301.77	0.5	NA	10%	20000	27	yes	

Equipment list currently includes 167 pieces of equipment from 32 manufacturers



SiPS TEA - Main

- Import and link equipment
 - Multiple work centers with different operating schedules possible
- Set throughput requirements
- Set standard prices
 - Electricity, natural gas, diesel, raw material, etc
- Set facility installation cost, if including

The screenshot displays the forestconcepts™ software interface. The main window is titled "fc SiPS_TEAv10_1". The interface includes a toolbar with icons for "Set Working Directory", "Define Source Material", "Import Equipment", "Add Equipment", "Add Workcenter", "Remove Workcenter", "Rename Workcenter", "Set Requirement", "Set Prices", and "Set Schedule". Below the toolbar, there are buttons for "View Imported Equipment", "Simulate", "Sensitivity Analysis", "Installation Cost", and "View Results". A "Notes" section is visible with a "Command Window" tab and a "Title" field containing "Preliminary Validation Model". The "Description" field contains the text: "- 13 pieces of equipment. - Crumbler - Dryer". The main data table, titled "Workcenter_1", lists equipment details for 13 items. A footer note states: "* Enter all distributions and percents in decimal form, e.g. enter 56% as 0.56."

Name	Tag	Name	Tag	Editing	ID	Type	In1	In2
Surge Bin - IMS 144024	0018	Surge Bin - IMS 144024	0018		1	Bin	source	-
Conveyor - EK450 (18x7)	0019	Conveyor - EK450 (18x7)	0019		2	Conveyor	Surge Bin - IMS 144024 (#0018).out1	Conveyor - EK450
M24M-30e Crumbler 4mm Head	0020	M24M-30e Crumbler 4mm Head	0020		3	Rotary Shear	Conveyor - EK450 (18x7) (#0019).out1	-
Conveyor - EK450 (18x7)	0021	Conveyor - EK450 (18x7)	0021		4	Conveyor	M24M-30e Crumbler 4mm Head (#0020).out1	-
Screen - BM&M 4x10SS	0022	Screen - BM&M 4x10SS	0022		5	Screen	Conveyor - EK450 (18x7) (#0021).out1	-
Conveyor - EK450 (18x7)	0026	Conveyor - EK450 (18x7)	0026		6	Conveyor	Screen - BM&M 4x10SS (#0022).out1	-
Surge Bin - IMS 144024	0027	Surge Bin - IMS 144024	0027		7	Bin	Conveyor - EK450 (18x7) (#0026).out1	-
Conveyor - EK450 (18x7)	0045	Conveyor - EK450 (18x7)	0045		8	Conveyor	Surge Bin - IMS 144024 (#0027).out1	-
Dryer - FC 123b	0028	Dryer - FC 123b	0028		9	Dryer	Conveyor - EK450 (18x7) (#0045).out1	-
Conveyor - EK450 (18x7)	0029	Conveyor - EK450 (18x7)	0029		10	Conveyor	Dryer - FC 123b (#0028).out1	-
Conveyor - EK450 (18x7)	0023	Conveyor - EK450 (18x7)	0023		11	Conveyor	Screen - BM&M 4x10SS (#0022).out2	-
Conveyor - EK450 (18x7)	0024	Conveyor - EK450 (18x7)	0024		12	Conveyor	Screen - BM&M 4x10SS (#0022).out3	-
Surge Bin - IMS 144024	0025	Surge Bin - IMS 144024	0025		13	Bin	Conveyor - EK450 (18x7) (#0024).out1	-



SiPS TEA – Equipment Details

- Tag/ID
- Life
- CAPEX
- Repair and Maintenance rate
- Electrical Power Consumption
 - User specified or calculated based on particle size change, material type, and size reduction type
- Natural Gas Consumption
 - User specified or calculated based on moisture change, particle size, material type
- Footprint
- Connections to other equipment

MATLAB App

Equipment Settings

Name: M24M-30e Crumbler 4mm Head

Tag: 0020

Life (hr): 40000

CAPEX (\$): 100000

RM Rate (%)*: 0.1

Floor Fraction (%)*: 0

Target MC (%)*:

Electrical Power (HP): 30 Use this value

NG Power (mmbtu/hr): 0 Use this value

Diesel Consumption (gal/hr):

Type: Rotary Shear

Queue Length (s): 2

Area (sqft): 100 Covered

Equipment Specific Area Multiplier: 2

ID Number: 3

Inputs

Input 1: Conveyor - EK450 (18x7) (#0019).out1

Input 2: -

Outputs

	Distro	Size	Density
	Must sum to 1	mm	odkg/m ³
1	Conveyor - EK450 (18x7) (#0021).in1	1	4
2	-	0	
3	-		

Inherit Inherit

Delete Accept Cancel



SiPS TEA – Facility Installation Cost

- Site upgrade costs
 - Electrical lines
 - Sewer lines
 - Fencing
 - Lighting
 - Paving
 - Catch basin
 - And more
- Building size multipliers of equipment footprint
- Site size based on building, uncovered area, catch basin ratios
- General costs ranges for each category
- Select only desired categories for inclusion

MATLAB App

forestconcepts™

Area Selection (for results calculation) Min

Min Area Expanded Area Loose Area

0.50 0.25 0.10

Percent of site covered by buildings / equip uncovered. (Express as a decimal.)

Item	Cost	3,100	12,400	31,000	Site Size (sqft)
Utilities					
<input checked="" type="checkbox"/> Water Mains (\$/ft)	40.00	\$ 4,454.21	\$ 8,908.42	\$ 14,085.45	Typical range: [\$15 - \$225].
<input checked="" type="checkbox"/> Sewer Lines (\$/ft)	150.00	\$ 16,703.29	\$ 33,406.59	\$ 52,820.45	Typical range: [\$50 - \$200].
<input type="checkbox"/> Septic Tank (\$/tank)	35000.00	\$ 35,000.00	\$ 35,000.00	\$ 35,000.00	Typical range: [\$20K - \$45K].
<input checked="" type="checkbox"/> Storm Drain to Pond (\$/ft)	100.00	\$ 5,567.76	\$ 11,135.53	\$ 17,606.82	Typical range: [\$50 - \$150].
					Typical range: [\$3K - \$8K].
Site Improvements					
<input checked="" type="checkbox"/> Waste Water Pond (\$/cuft)	0.75	\$ 1,162.50	\$ 4,650.00	\$ 11,625.00	Typical range: [\$0.30 - \$1].
<input checked="" type="checkbox"/> Parking / Driveways Paved (\$/sqft)	5.00	\$ 6,200.00	\$ 24,800.00	\$ 62,000.00	Typical range: [\$3 - \$7].
<input type="checkbox"/> Parking / Driveways Gravel (\$/sqft)	3.00	\$ 3,720.00	\$ 14,880.00	\$ 37,200.00	Typical range: [\$1 - \$5].
<input checked="" type="checkbox"/> Perimeter Fence (\$/ft)	25.00	\$ 5,567.76	\$ 11,135.53	\$ 17,606.82	Typical range: [\$8 - \$40].
					Typical range: [\$80 - \$375].
Total	\$ 512,355.53	\$ 71,736.07	\$ 663,444.54		

Plot Accept



SiPS TEA - Results

- Mass and energy balances for each week
- Daily (with work center scheduling) mass and energy balances
- Calculation of quantities of equipment pieces based on inputs
- Total CAPEX
- Total OPEX
- Export to MS Excel

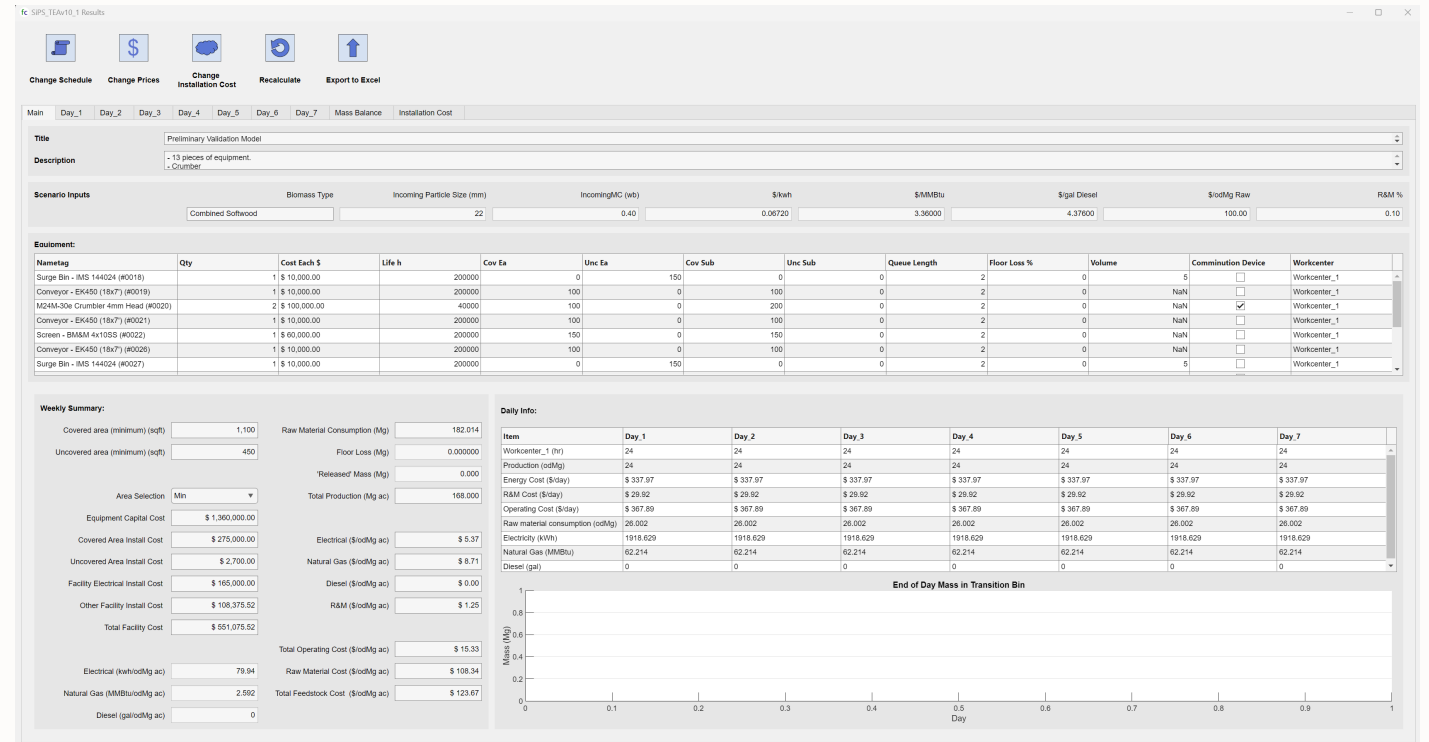

Results

- Appreciative design reduces project failures and “yeah, but” delays
- Project planners can have good mass and energy balances early in the planning phase to prevent “gotchas”
- TEA parameter adjustments are relatively easy
- Result is lower technical, operational, and financial risk



Results (2)

- Modular preprocessing equipment to “plug and play” will speed facility installation and planning

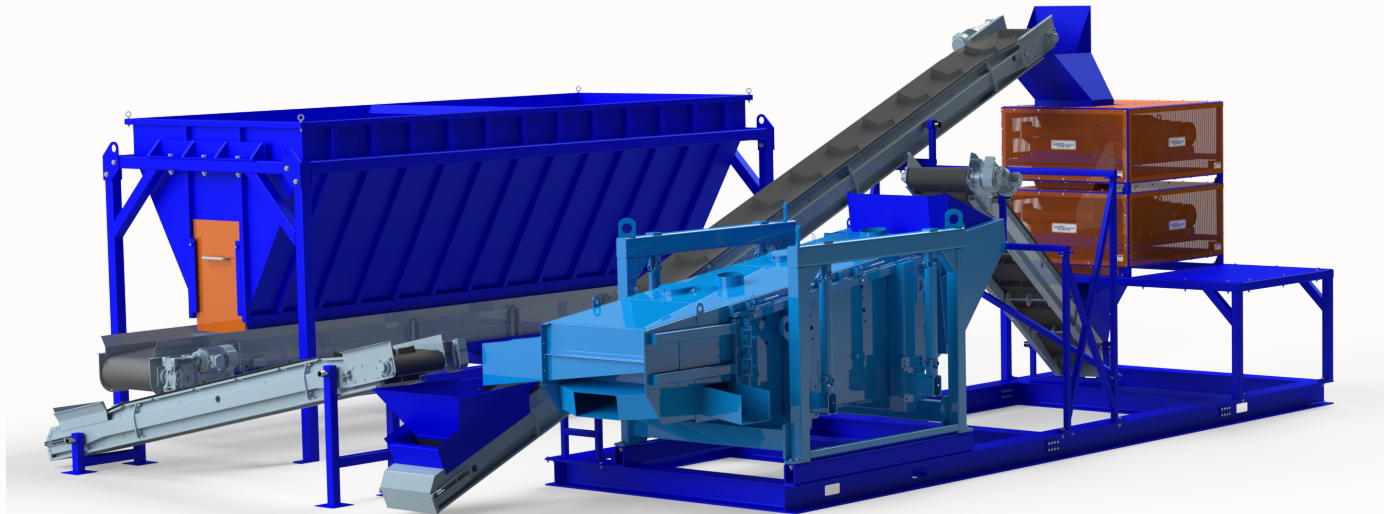

Where We Go From Here

- Work with additional developers to continue process validation
- Model additional work centers beyond feedstock preprocessing (conversion, etc)
- Add equipment and manufacturers to the equipment list
- Place Feed/Comminution module with partner for validation testing



Acknowledgements

This material is based upon work supported by the U.S. Department of Energy, Office of Science, Office of Energy Efficiency & Renewable Energy, and Bioenergy Technologies Office Small Business Innovation Research Program under Award Number DE-SC0022702.

Disclaimer

This report was prepared as an account of work sponsored by an agency of the United States Government. Neither the United States Government nor any agency thereof, nor any of their employees, makes any warranty, express or implied, or assumes any legal liability or responsibility for the accuracy, completeness, or usefulness of any information, apparatus, product, or process disclosed, or represents that its use would not infringe privately owned rights. Reference herein to any specific commercial product, process, or service by trade name, trademark, manufacturer, or otherwise does not necessarily constitute or imply its endorsement, recommendation, or favoring by the United States Government or any agency thereof. The views and opinions of authors expressed herein do not necessarily state or reflect those of the United States Government or any agency thereof.



Thank You!

Dave Lanning - Senior Engineer
dlanning@forestconcepts.com
253.333.9663

Forest Concepts, LLC
3320 W. Valley Hwy. N., D110
Auburn, WA 98001

